



SPECIFICATIONS

SIZES

- Panel: 42" x 55", 58" x 55", 64" x 55", 70" x 55"
- Urinal Screens: 24" x 48"
- Doors: 24" x 55", 36" x 55"
- Pilasters: 3", 4", 7", 8", 10", 12", 20", 24" (x 82")

HARDWARE

- Brackets:** Aluminum or plastic, continuous aluminum, stainless steel or plastic
- Shoes:** Stainless steel or plastic
- Hinges:** 8" wrap around aluminum, continuous aluminum or stainless steel
- Door Hardware:** 54" continuous strike with surface-mounted slide latches (ADA)

COLOR & TEXTURE



TEXTURE KEY: **OP** ORANGE PEEL

*Color matching is limited by printing process.
Actual samples available and are recommended prior to color selections.
All swatches shown in Orange Peel.*

WE CALL IT RESISTALL FOR A REASON

New Resistall Partitions stand tough over time with many features and benefits. Unlike metal partitions, they are impermeable to moisture and will never rust or need painting. In addition, Resistall Partitions will not delaminate and are built to resist mildew, odors, corrosion and dents, saving you the added costs of maintenance.

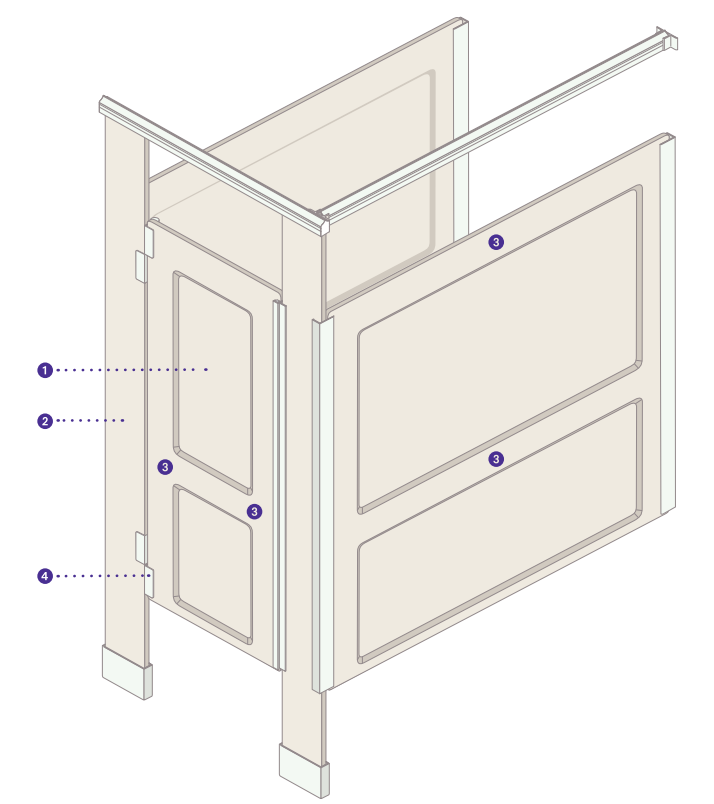

- 1 Paneled Design**
This unique aesthetic touch on the doors and side panels delivers a premium look and feel.
- 2 Orange Peel Texture**
Reduces signs of wear and deters graffiti, keeping interiors looking great for years to come.
- 3 Strength Reinforcements**
Meeting ADA compliance for grab bars, our door and side panel reinforcements provide added durability.
- 4 Worry-free Hardware**
To complement any interior, we offer an array of great-looking hardware options.

HDPE PLASTIC vs METAL & PLASTIC LAMINATE

A HEAD-TO-HEAD COMPARISON

	RESISTALL HDPE PLASTIC	METAL (POWDER COATED)	PLASTIC LAMINATE
Warranty	5 YEARS	@ 3 YEARS	@ 2 YEARS
Impact resistant (up to 500 lbs)	●	-	●
Maintenance free	●	-	-
Homogenous color (color throughout)	●	-	-
Non porous (will not absorb odors)	●	-	-
Scratch resistant	●	-	-

AS DURABLE AS IT IS AFFORDABLE



From the leader of the partition industry for over 25 years comes a new privacy alternative: Scranton Products' Resistall Partitions. This new line of maintenance-free partitions is engineered for value-oriented customers looking to save time and avoid hassles. These new built-tough partitions offer easy installation and a longer life cycle with a 5-year warranty. The Resistall Partitions line is just one more example of Scranton Products' unwavering passion for quality and innovation.

BATHROOM PARTITIONS
LOCKERS
LOCKER ROOM BENCHES
SHOWER CUBICLES
DRESSING COMPARTMENTS
VANITIES

WE DON'T JUST TALK TOUGH. WE BACK IT UP.

Proudly made in the USA, Scranton Products' brands provide industry-leading protection. Because Scranton Products is so confident that our Resistall Partitions will stand the test of time, they're backed with a full 5-year warranty covering breakage, corrosion and delamination under normal conditions.

EASY ON THE ENVIRONMENT.

As the industry leader in responsible recycling, Scranton Products is committed to reducing industrial waste. We reclaim all of our scrap and off-cuts into production to create new sheets. Incorporating our HDPE plastic products can contribute points toward LEED certification.

Call 800.445.5148 for the Scranton Products sales representative in your area, or visit scrantonproducts.com.



Scranton Products
801 E. Corey Street
Scranton, PA 18505
800.445.5148
Fax: 800.551.6993
info@scrantonproducts.com
www.scrantonproducts.com



RESISTALL PARTITIONS™